

COMPACT SWING DOOR OPERATOR

KONE UniSwing™ Compact

KONE UniSwing™ Compact door operator features a powerful and a low noise level, fully-automatic door operator, suitable for single and double doors. It can be adjusted for the demands of many environments and meets all requirements for barrier-free construction and living.

Applications

- Single & double swing doors

KONE UniSwing™ Compact

Construction

- Electromechanical operator with low-voltage motor, control unit and transmission arm to connect to the door leaf
- Integrated in aluminium housing
- Application in pulling or pushing configuration

Operating modes

- Manual operated activators (push buttons and switches)
- Motion detectors
- Safety sensors
- Remote control
- Entrance control system
- Optional wireless program switch

Function programs via

Standard PGS:

- Automatic
- Open
- Manual

Wireless program switch:

- Automatic
- Open
- One way
- Closed
- Manual
- Sequential opening
- Porter open
- Reset

Special functions included as standard

- Push and Go
- Night
- Fire input function
- Wind stack

Optional functions

- Sequential opening function
- Timer sequential opening
- Pulse-open/Pulse-close function

- Master/Slave
- Low Energy
- Spring compensation mode
- Pulse/Automatic mode
- Close sequencer
- Slave delay mode
- Toilet mode

Locking

- Depending on door frames and door leaf

Safety features

- Electronic safety reverse (highly sensitive reverse settings in open and close directions)
- Finger trap safety (depending on door frame and profile)
- Door speed safety (automatically adjusted based on door weight and resistance)
- Power failure (all settings are stored in case of power failure unless door is in locked position)
- Optional safety features, for example infrared safety sensors

Double swing door (optional)

- Double door operator integrated into an extended housing
- Opening and closing sequence based on master/slave configuration

Accessory connections

- KONE safety sensors (mounting on both hinge and opposite hinge sides)
- Door locking device
- Electric strikes (fail safe/fail secure)
- Access control system
- Activators
 - Pushbuttons
 - Motion detector
- Radio remote control
- External program switch (wireless PGS)

Applications

- Single and double-leaf swing doors
Operator variant Pushing / Pulling
- Opening width for single-leaf doors (door leaf width)
Operator variant Pushing / Pulling
- Opening width for double-leaf doors (door leaf width) 2x single door
Operator variant Pushing / Pulling



| Door Technical Features | |
|-------------------------------|--|
| Max. door weight | 300kg (at door width of 700mm) |
| Max. door width | 1100mm (at door weight of 120kg) |
| Opening angle | 105° |
| Single door pushing DIN-L | Available |
| Single door pushing DIN-R | Available |
| Single door pulling DIN-L | Available |
| Single door pulling DIN-R | Available |
| Double door pushing | Available |
| Double door pulling | Available |
| Double door pushing / pulling | Option |
| Reveal | -25 to +140mm |
| Operator colour | Standard Aluminum anodized RAL Option |

Note: In automatic operation the swing area of the door must always be secured with safety motion detectors.

Maximum Door width at maximum door weight

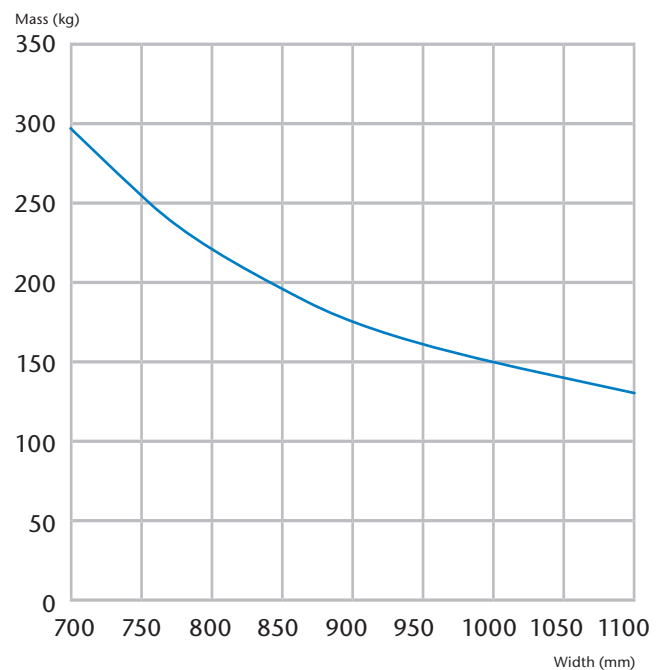

Speed profile: when opening

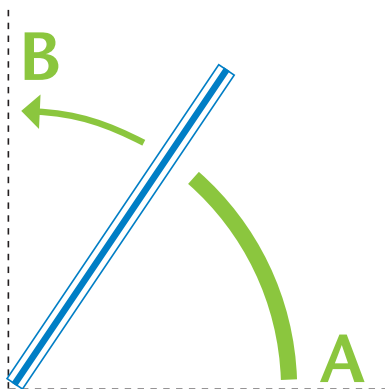

When opening:

- A: First part of opening movement at high speed
B: Last part of opening movement at low speed

Speed profile: when closing

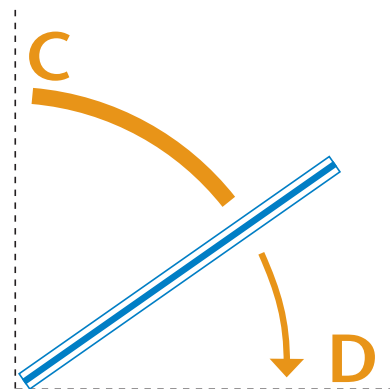

When closing:

- C: First part of closing movement at high speed
D: Last part of closing movement at low speed

Components overview

- A** PGS selector and reset button
- B** Controller unit
- C** Transformer
- D** Motor and gearbox
- E** Bevel gearbox
- F** Connection board
- G** Mains power cable
- H** Door arm
- I** Sliding profile
- J** Cover Plate

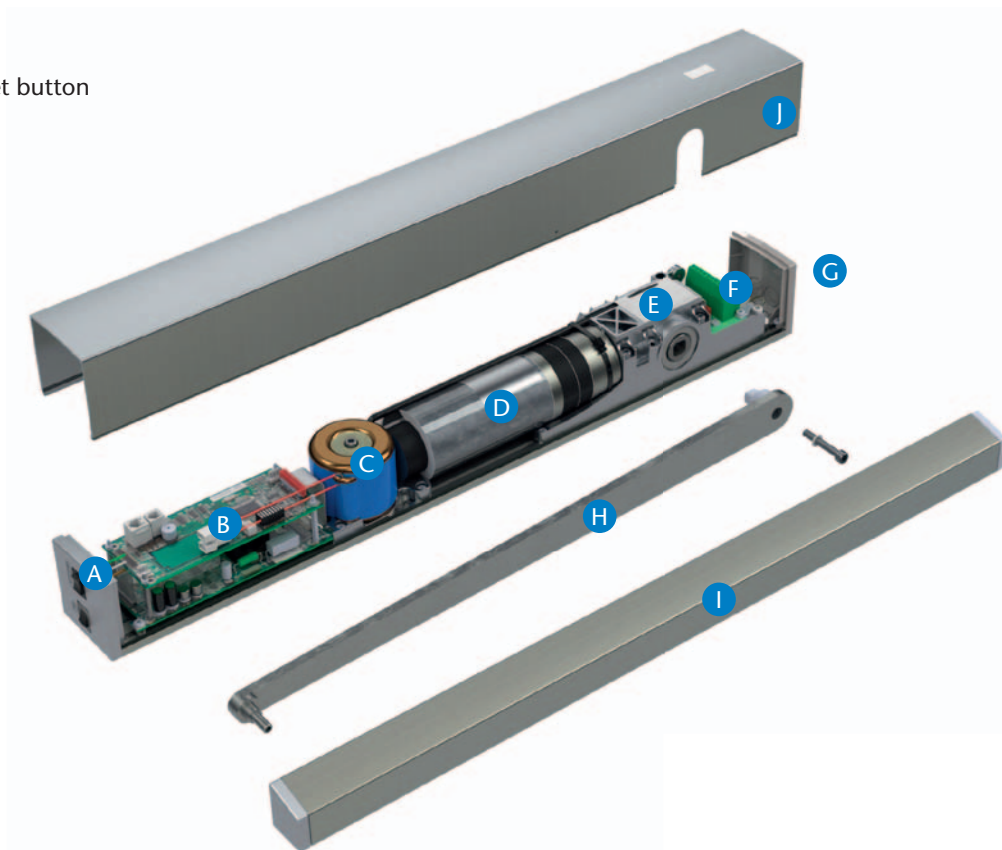

Drive Unit Technical Data

The electromechanical swing door operator, with a permanent magnet DC motor and gear drive in conjunction with an electronic controller and supplementary safety sensors, provides low energy consumption and quiet, smooth door motion, without compromising traffic flow in the building.

| Drive Unit | |
|---|---|
| Dimensions | Height 75 mm Depth 75 mm Width 700 mm |
| Slide arm | Pushing and Pulling |
| Weight | 8.2 kg |
| Weight + mounting plate | 9.4 kg |
| Power consumption | 70W |
| Supply voltage | 230VAC 50/60 Hz |
| Power supply for external accessories (e.g. sensors and lock) | 24VDC/24W |
| Temperature range | -15° to +50°C |
| Maximum torque | 54Nm on output shaft < 150N on door leaf |
| Humidity range | (non-condensing) max. 85% |
| Protection class | IP20 |
| Extended cover for single and double-leaf door | Yes |
| TÜV approved | Yes |
| Compliant with the low-voltage directive | Yes |
| Compliant with EMC directive | Yes |
| Produced to both ISO 9000 and 14001 standards | Yes |
| Compliant with Machine directive 2006/42/EC | Yes |
| Program switch | 3 stage hardware Auto/Open/Manual |
| Reset switch | Yes |

| Adjustable parameter of driving phase | |
|---|------------------------------------|
| With slide channel mounting on the hinge (pull side) | Opening angle, max. 105° |
| With slide channel mounting on the opposite hinge (push side) | Opening angle, max. 105° |
| Opening times | ≥3sec |
| Closing times | ≥5sec |
| Hold-open time | 0-60sec |
| Wall blanking for safety sensors | Yes, adaptive, software controlled |
| Break distance (Trajectory at low speed) | Fixed, meets DIN18650 |

Installation variants

The swing door operator is very flexible and can be used with all opening types and with DIN left and DIN right doors.

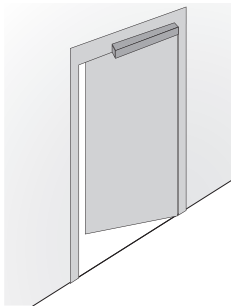

Lintel installation
(1-leaf door)
Slide arm DIN left or right pushing

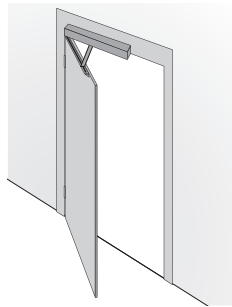

Lintel installation
(1-leaf door)
Standard arm DIN left or right pulling

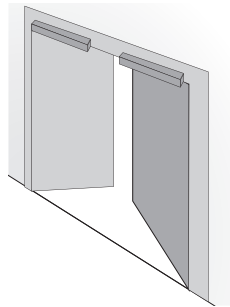

Lintel installation
(2-leaf door, master / slave operation)
Two electrically coupled drives with standard arm pushing

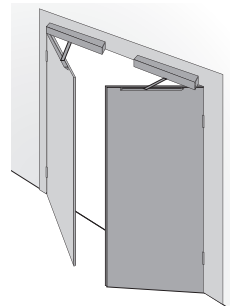

Lintel installation
(2-leaf door, master / slave operation)
Two electrically coupled drives with standard arm pulling

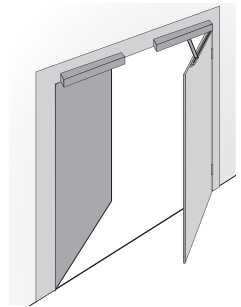

Lintel installation
(2-leaf door with two-way traffic)
Alternating operation of two drives

Assembly pulling

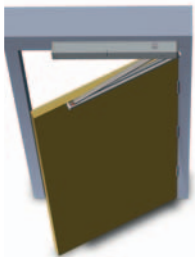

Door frame front view pulling

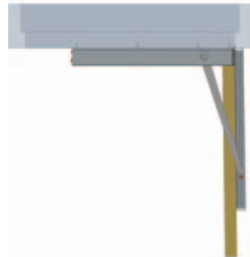

Door frame top view pulling

Assembly pushing



Door frame front view pushing

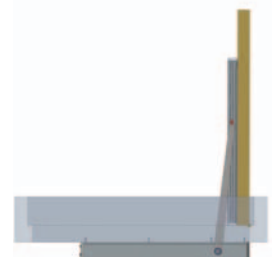

Door frame top view pushing

Control Unit: Standard and optional functions

- The control unit, with a microprocessor and integrated safety solutions, offers the possibility to connect manual and automatic activation units, position switches and presence detectors.
- The advanced microprocessor controller and safe encoder technology work together for precise and comprehensive control of the doors' motion.
- The controller ensures trouble-free operation with the specifications below.

Terminology

- Reveal** Distance between door and lintel
SAPU Swing Area Protection unit
DIN-L Left opening door according to DIN 107
DIN-R Right opening door according to DIN 107
RC-PGS Program switch, wireless, operates over radio 433MHz
PGS Program switch



Accessories

| Function programs via program switch | PGS | RC_PGS |
|--|------------------------|--------|
| Automatic | Yes | Yes |
| Manual | Yes | Yes |
| Open | Yes | Yes |
| One way | | Yes |
| Airlock mode | | Yes |
| Reset | Yes | Yes |
| Porter open | | Yes |
| Special functions included as standard | KONE UniSwing™ Compact | |
| Push And Go | | Yes |
| Night | | Yes |
| Fire input function | | Yes |
| Wind stack | | Yes |
| Optional functions | KONE UniSwing™ Compact | |
| Sequential opening function | | Yes |
| Timer sequential opening | | Yes |
| Pulse-open/Pulse-close function | | Yes |
| Master/Slave | | Yes |
| Low energy | | Yes |
| Pulse/Automatic mode | | Yes |
| Close sequencer | | Yes |
| Slave delay mode | | Yes |
| Toilet mode | | Yes |

Wiring diagrams

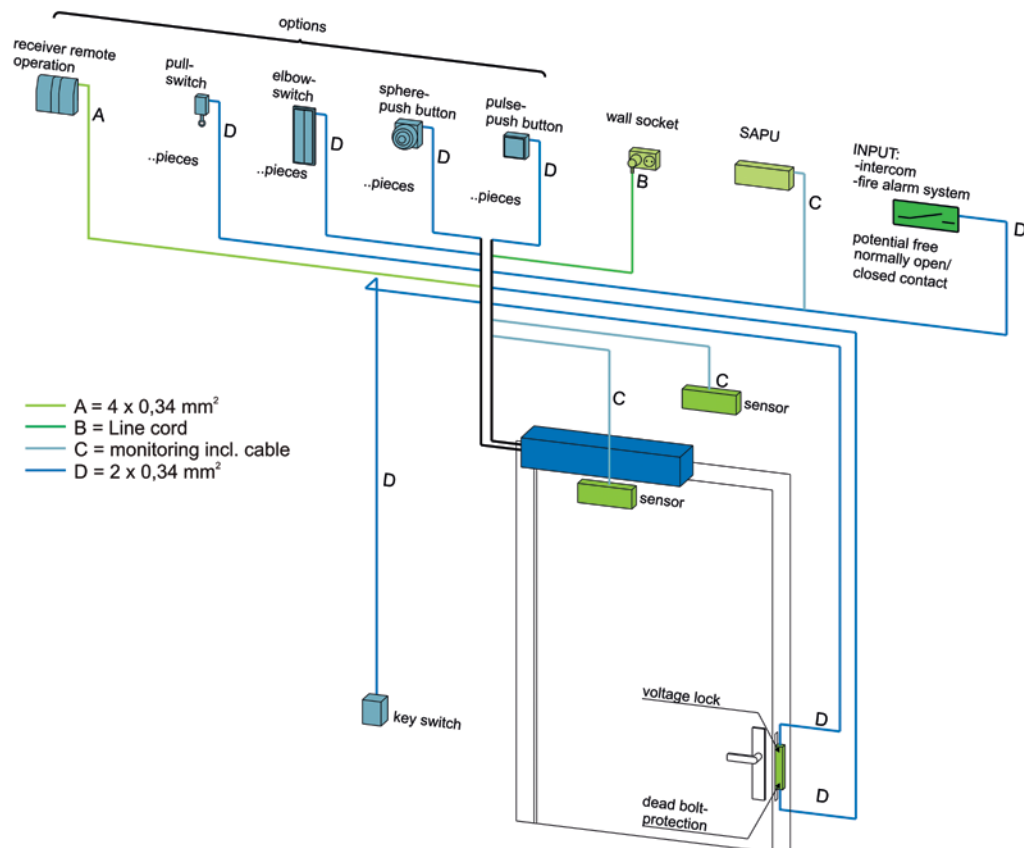



KONE provides innovative and eco-efficient solutions for elevators, escalators and automatic building doors. We support our customers every step of the way; from design, manufacturing and installation to maintenance and modernization. KONE is a global leader in helping our customers manage the smooth flow of people and goods throughout their buildings.

Our commitment to customers is present in all KONE solutions. This makes us a reliable partner throughout the life-cycle of the building. We challenge the conventional wisdom of the industry. We are fast, flexible, and we have a well-deserved reputation as a technology leader, with such innovations as KONE UniDrive® and KONE Hermetic Sealing Doors. You can experience these innovations in architectural landmarks such as the Philips headquarters in Eindhoven, the Netherlands; the Metro Italia in Milan, Italy; the Sahlgrenska Sjukhuset hospital in Gothenburg, Sweden; and the Academic Medical Center in Amsterdam, the Netherlands.

KONE employs approximately 34,000 dedicated experts to serve you globally and locally in over 50 countries.

KONE Corporation
www.kone.com