

# User instruction KONE UniSwing Compact Swing Door Operator

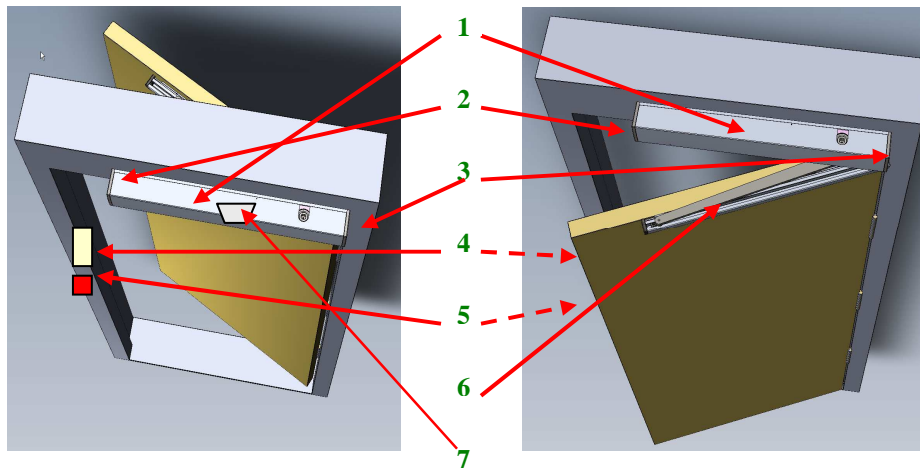

Pushing version

Pulling version





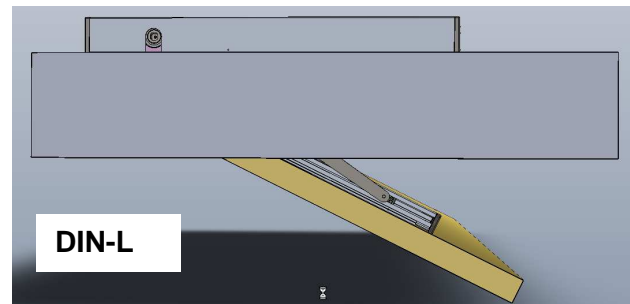
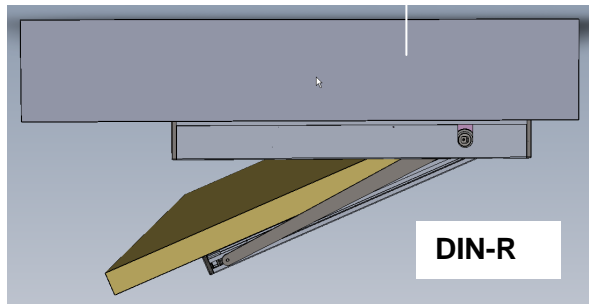

- 1) Swing door operator with cover
- 2) Programme selector
- 3) Line cable (230V AC with earth)
- 4) Electrical lock (option)
- 5) Switch / Pushbutton
- 6) Door arm
- 7) Motion detector / signals



## Programming selector button and separate Reset button

The programming selector button (PGS) is mounted in the side panel the door operator. The PGS can be set in the following modes:

-  Automatic mode
-  Manual mode
-  Open mode
-  Reset button

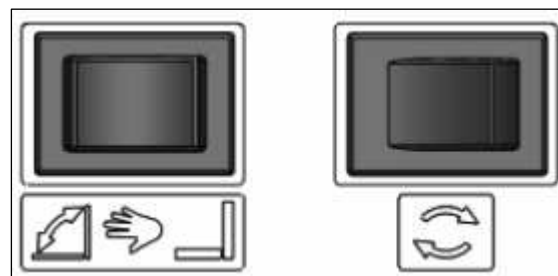

When the PGS is set in Manual mode, an optional remote control PGS can be used to change the program switch settings. When either one of the other functions of the PGS was selected (Open or Automatic) the RC\_PGS will be ignored.

The Reset button is used for the reset function of the door controller. A short actuation of the button will clear all errors, if any. When the button is pressed for more than 5 seconds without interruption, the door controller will reset and start again.

## Buzzer

In case of an error, the buzzer will sound during 30 seconds (and 5 sec. after each PGS change) in a code which corresponds with the actual cause. See also the manual for error codes. See Reset for clearing and resetting an error.

## Power failure

During power failure, the door is (light) manually to open and to close, except when the door is locked in closed position. All values of the door controller stay memorized.

## Attention!

- The KONE automatic sliding and swing door operators are designed to open and close door leafs as reliably as possible and to grant persons a safe passage. To prevent persons for dangerous situations it is not advisable to stand continuously in the swing area despite of a built in safety reverse.
- If the door operator is damaged, people can get injured or cause any other damage because of improper use or improper application of technical data and/or equipment. KONE Deursystemen B.V. will accept no liability, supply parts under guarantee, or carry out repairs.
- Only Qualified people should carry out electrical connections to the electrical installations and mains.

## Service

You have just bought a quality product which is manufactured compliant with the European regulations. Notwithstanding the high quality of this product it is possible that, under certain circumstances, the door doesn't operate correctly. Please find below a check list and see if you can solve the problem yourself, i.e. time saving, before contacting your service contractor:

- ✓ Is the line power present?
- ✓ Is the correct position selected on the program switch, i.e. automatic mode?
- ✓ Are the sensors clean and uncovered?
- ✓ Are the door leafs not obstructed and are they able to open maximally?
- ✓ Is a possible emergency button pressed?
- ✓ Is a possible fire alarm contact switched on?
- ✓ Does activating the RESET button by the program switch solve the problem?
- ✓ Does a system restart i.e. keep for 5 seconds the RESET button pressed, solve the problem?
- ✓ Does switching off and on the line power solve the problem, i.e. hard reset?

If you were not able to solve the problem please contact your nearest dealer.

You can also visit our website for more information: [www.kone.com](http://www.kone.com) or [www.waldoor.com](http://www.waldoor.com)

